

**ATTACHMENT 6**  
**PREPAREDNESS AND PREVENTION PLAN**

Table of Contents

- 1.0 Container Storage Facility – Bldg. 528.....1
  - 1.1 Emergency Equipment.....1
  - 1.2 Operating Requirements .....1
  - 1.3 Preventative Procedures, Structures, and Equipment .....2
  - 1.4 Inspections and Maintenance.....3
  
- 2.0 PEP Container Storage Facilities – Bldgs, A101, C815, C816, 1368, 1370, 1205 .....3
  - 2.1 Emergency Equipment.....3
  - 2.2 Operating Requirements .....4
  - 2.3 Preventative Procedures, Structures, and Equipment .....4
  - 2.4 Inspections and Maintenance.....5
  
- 3.0 Deactivation Furnace .....5
  - 3.1 Emergency Equipment.....5
  - 3.2 Operating Requirements .....6
  - 3.3 Preventative Procedures, Structures, and Equipment .....6
  - 3.4 Inspections and Maintenance .....7
  
- 4.0 Small Caliber Disassembly Line.....7
  - 4.1 Emergency Equipment.....7
  - 4.2 Operating Requirements .....8
  - 4.3 Preventative Procedures, Structures, and Equipment .....8
  - 4.4 Inspections and Maintenance.....9
  
- 5.0 Open Burning/Open Detonation area.....9
  - 5.1 Internal Communications.....9
  - 5.2 Reutilization and External Communications .....9
  - 5.3 Fire and Spill Control.....10
  - 5.4 Equipment Testing and Maintenance.....10
  - 5.5 Contingency Arrangements and Coordination Agreements .....10
  - 5.6 General Hazard Prevention .....11
    - 5.6.1 Loading and Unloading Operations .....11
    - 5.6.2 Runoff .....12
    - 5.6.3 Water Supplies .....12
    - 5.6.4 Equipment and Power Failures .....12
    - 5.6.5 Personnel Protection Procedures.....12
    - 5.6.6 Releases to the Atmosphere .....13
    - 5.6.7 Prevention of Accidental Ignition or Reaction of Waste .....13
  
- 6.0 Hydrolysis Facility .....14
  - 6.1 Emergency Equipment.....14
  - 6.2 Operating Requirements .....14
  - 6.3 Preventive Procedures, Structures and Equipment .....15
  - 6.4 Inspections and Maintenance.....16

Appendix A. Location of Emergency Equipment.....	17
Figure A-1 Building 528.....	18
Figure A-2 Igloo A-101 .....	19
Figure A-3 Igloo C-815 & C-816 .....	20
Figure A-4 Service Magazines 1368 & 1370 .....	21
Figure A-5 Above Ground Magazine 1205 .....	22
Figure A-6 Building 1320.....	23
Figure A-7 Building 1325.....	24
Figure A-8 OB/OD Area.....	25
Figure A-9 Building 1400.....	26
 Appendix B. List of Reciprocal Agreements.....	 27

## **PREPAREDNESS AND PREVENTION PLAN**

### **1.0 Container Storage Facility – Bldg. 528**

#### **1.1 Emergency Equipment**

- a) Alarm System: Internal communication and alarm is achieved by a hand-held telephone or voice. The facility is small (75ft x 75ft) and generally no more than two people work in the facility at the same time.
- b) Device for Summoning External Assistance: A telephone is located just inside the exterior door of the facility to be used for summoning external help or emergency assistance. The operator of the facility will also have a hand held telephone available for summoning assistance.
- c) Access to Communications or Alarm Systems: Whenever the facility is in use, employees will communicate by voice with others present. Employees will use the telephone for summoning external emergency assistance. If only one person is working in the Container Storage Facility (CSF), a hand held telephone will remain within immediate reach for summoning external emergency assistance.
- d) Fire Control Equipment: Two portable fire extinguishers are located at the CSF. The location of the fire extinguishers is given in the drawing of Building 528 in Appendix A.
- e) Spill Control Equipment: A spill kit containing Tyvek suits, absorbent material, gloves, boots, face shields, and safety glasses or goggles is located at the CSF. The location of the spill kit is given in the drawing of Building 528 in Appendix A.
- f) Decontamination Equipment: An eye wash and an emergency shower are located at the CSF. The location of this equipment is in the drawing of Building 528 in Appendix A.

#### **1.2 Operating Requirement**

- a) Adequate Aisle Space: A minimum aisle space of 30 inches shall be maintained between the rows of pallets. This space will allow for inspections, use of fire extinguishers, and spill control equipment, if necessary.
- b) Arrangements with Local Authorities: Tooele Army Depot (TEAD) will maintain reciprocal agreements with area fire departments, law enforcement agencies and hospitals. A list of the local authorities that TEAD has agreements with is given in Appendix B of this plan. TEAD has its own fire department and security organizations, who will be the primary responders to emergencies. This plan and others dealing with hazardous waste management are reviewed by these organizations so that they may become familiar with hazards and properties of the materials, and the facilities at TEAD.

c) Water for Fire Control: Fire hydrant no. 31 is within 500 ft. of CSF, with a total flow of 3125 gpm at a static pressure of 82 psi. Fire hydrant no. 20 is within 700 ft, and has a total flow of 2000 gpm at 80 psi static pressure.

### **1.3 Preventative Procedures, Structures and Equipment**

a) Unloading Operations: The following procedures, structures, and equipment are used to minimize hazards: forklift (high weight capacity) is used; a limit of four drums per pallet is adhered to; stronger hardwood (oak) pallets are used; a full concrete ramp exists leading to the main door; no docks are used; delivery trucks are backed onto the ramp in winter to avoid snow and ice during loading/unloading; operators are trained and licensed for operating material handling equipment; a minimum of two persons are present when the contractor is present for loading; slings, drums handlers, etc. are available for safely handling single drums.

b) Run-off Control: The CSF is totally enclosed and weather tight. All spills will be immediately cleaned up and neutralized using absorbents stored in the immediate area. Toxic spills will be decontaminated by the fire department Haz Mat team.

c) Mitigation of the effects of Equipment Failure or Power Outage: Power is used only for lighting in the DSF. Lighting is only used in early hours in the winter, and the forklift has headlights which could be used in the event of a power outage. An extended power outage in the winter could result in freezing of the emergency shower. If this happened, operations would be shut down until all safety and decontamination equipment was functional, or provisions for temporary equipment were made.

d) Prevention of Contamination of Water Supplies: Contamination of water supplies is prevented by minimizing the probability of releasing hazardous waste (HW) into the environment by proper HW handling practices. Regular inspections, adherence to safety procedures, prompt clean up of spills, and sufficient training of all employees working in the CSF are examples of proper HW management practices. In addition, a 20 mil liner is in place under the CSF as an additional precaution in the event that HW constituents penetrated the floor of the CSF. The floor of the CSF is sealed and divided into four separate cells by concrete curbing, and a six-inch concrete curb around the perimeter prevents spilled liquids from escaping the building.

e) Personnel Protection Equipment: No personnel protective equipment is used under normal conditions. If there is leakage or a spill, the following personnel protective items are available in the spill kit. Tyvek suites, gloves, boots, face shields and safety glasses or goggles.

f) Precautions to Prevent Ignition or Reaction of Ignitable or Reactive Waste: Waste of different compatibility types are stored in separate cells, smoking is prohibited in the CSF, non ferrous metal tools are used, explosion proof lighting is installed, and there are no electrical outlets in the CSF.

## **1.4 Inspections and Maintenance**

The spill control, fire and decontamination equipment is inspected weekly by the operators when the area is in use.

If any of the spill control or decontamination equipment is incomplete or deficient the Environmental Office (EO) will provide whatever is needed to maintain the spill control equipment. EO will also initiate work orders to Facilities Engineering Division to repair or replace any decontamination equipment (emergency eye wash and shower).

## **2.0 PEP Container Storage Facilities – Bldgs. A101, C815, C816, 1368, 1370, 1205**

### **2.1 Emergency Equipment**

a) Alarm System: Internal communication and alarm functions are achieved by voice and by two-way radio. These facilities are small and voice is the most efficient method for alarm and internal communication. Generally, there are no more than two people working at these facilities at a given time.

b) Device for Summoning External Assistance: Personnel, when working at any of these locations, are required to have a hand-held phone and/or two-way radio immediately available which can be used for summoning external assistance in an emergency.

c) Access to Communications or Alarm Systems: Whenever personnel are working at any of these facilities, voice communications are used to communicate between those present. A portable two-way radio or a hand-held phone will be within immediate reach for summoning external emergency assistance. If only one person is working at these facilities, a portable hand-held radio or hand-held phone will remain within immediate reach for summoning assistance.

d) Fire Control, Spill Control, and Decontamination Equipment: Each facility has a 10 lb. A, B, C chemical/electrical dry powder type of fire extinguisher. The location of the fire extinguishers is shown on the attached sketches. A portable eyewash will always be present when personnel are working in igloo A101 where liquid wastes may be stored. Portable showers are not provided because the substances stored have low toxicity and are non-corrosive.

e) Spill Control Equipment: A spill kit containing Tyvek suits, absorbent material, gloves, safety glasses or goggles, and boots will be available just inside the door of igloo A101. The location of the spill kit is provided in sketch A101. Spill kits are not provided at the remaining PEP storage facilities, as they will not store any liquid hazardous waste.

f) Decontamination Equipment: A portable eyewash will be present whenever personnel are working in Igloo A101.

## **2.2 Operating Requirements**

- a) Adequate Aisle Space: A minimum of 30 inches of aisle space will be maintained between stacks of pallets in these storage facilities. This space is sufficient to allow inspection of containers, used of spill control equipment, and fire control equipment.
  
- b) Arrangements with Local Authorities: Tooele Army Depot will maintain reciprocal agreements with area fire departments, law enforcement agencies and hospitals. A listing of the local authorities that TEAD has agreements with is given in Appendix B of this plan. TEAD has its own fire department and security organizations, which will be the primary responders to emergencies. This plan and others dealing with hazardous waste management are reviewed by these organizations so that they may become familiar with the hazards and properties of the materials, and the facilities at TEAD.
  
- c) Water for Fire Control: Only fires that are outside of the PEP igloos are fought (i.e. grass fires, etc.) and these fires are fought with pumper trucks only. In general, the fire department will respond to fires in the ammo storage area igloos only to the quantity/distance line, beyond which shrapnel etc. is not expected to reach. Fires outside of ammunition storage igloos are not fought because of explosion danger. Water for refilling pumper trucks is available from water troughs and fire hydrants at distances ranging from 1000 to 3200 feet from the PEP CSFs.

## **2.3 Preventative Procedures, Structures, and Equipment**

- a) Unloading Operations: Proper techniques for transportation and handling as outlined in SOPs include grounding when exposed propellant is present, prohibition of smoking and open flames, prohibition of spark producing devices, and use of non sparking tools and material handling equipment.
  
- b) Run-off Control: Run-off control is provided by the fact that the six PEP CSFs are totally enclosed and weather tight. Wastes which could contain free liquids would be stored only in Igloo A101. This igloo has the following additional modifications for safe storage of liquids: sealed drain gutters, crowned floor which drains towards gutters, the floor was sealed with masonry patch and rubber based paint.
  
- c) Mitigation of the Effects of Equipment Failure or Power Outage: In the event of equipment failure or power outage, operations will cease until the faulty equipment is either repaired or replaced.
  
- d) Prevention of Contamination of Water Supplies: Contamination of water supplies is prevented by minimizing the risk of discharge through frequent inspections, training, adherence to SOPs, and prompt clean up of spills. All of the PEP CSFs are enclosed so that spilled solids will be contained. Igloo A101 has a sealed floor and sealed drain gutters to contain spilled liquids.

e) Personnel Protection Equipment: Personnel working in these facilities are equipped with coveralls and leather gloves. Since the substances stored in these facilities are non-corrosive and have a low toxicity, other personal protective equipment is not normally used. In the event of a spill in Igloo A101, tyvek suits, gloves, boots and safety glasses or goggles are available in the spill kit.

f) Precautions to Prevent Ignition or Reaction of Ignitable or Reactive Waste: A system of fusible links provides some protection from fires outside of the igloos by closing air vents when the outside temperature becomes too high. Proper storage and handling techniques, as outlined in SOPs, include: grounding, prohibition of smoking and open flames, prohibition of any spark producing devices, and all cotton clothing to reduce static electricity accumulation. No electrical outlets or lighting are present in these facilities.

## **2.4 Inspections and Maintenance**

The spill control, fire, and decontamination equipment are inspected weekly by the operators when a building is in use. If any of the spill control or decontamination equipment is incomplete or deficient the operator will provide whatever is needed to maintain the spill control equipment. The decontamination equipment will be inspected and maintained by Ammunition Operations personnel.

## **3.0 Deactivation Furnace – Bldg. 1320**

### **3.1 Emergency Equipment**

a) Alarm System: The deactivation furnace is operated remotely from the control room (see attached sketch). Personnel access to the inside of the concrete/metal walls around the furnace is restricted during processing of PEP items. Alarms (audible beeping, flashing lights on control board) are built into the automated control system which alerts the operators to emergency situations. Other personnel working in the area are alerted by voice communication.

b) Device for Summoning External Assistance: A telephone is located inside the control room with an additional phone located outside of the facility on the northwest corner, which can be used for summoning external help or emergency assistance.

c) Access to Communications or Alarm Systems: When the furnace is in use, employees will have immediate access to communications and alarm systems by voice communication and telephone. While the Deactivation Furnace is operating (treating wastes) there will always be more than one person present.

d) Fire Control Equipment: Two fire extinguishers of the dry powder type (A, B, C chemical, electrical, rubbish) are present. The locations of the fire extinguishers are given in the drawing of Building 1320 in Appendix A.

e) Spill Control Equipment: No liquids are stored or treated at this facility and therefore only brooms and dust pans are provided for the collection of any ash that may spill onto the floor.

f) Decontamination Equipment: An eyewash will be present at all times during operation of the incinerator. A portable shower is not necessary because the wastes processed are relatively non-toxic and non-corrosive.

### **3.2 Operating Requirements**

a) Adequate aisle space: The aisle space (space around the equipment) of the deactivation furnace system is provided in the attached figure in Appendix A. The equipment layout was designed to allow easy inspection, maintenance, and removal/replacement of the installed equipment. This spacing is also adequate for spill control activities. No combustible materials other than the fuel and feedstock items are present. The spacing is adequate for fighting fires of ordinary combustible materials (non PEP materials). No PEP materials are stored at the facility. During operation, only the quantity of PEP materials that are to be processed that day, are brought to the feed room. If for some reason these items are not processed, they will be returned to a permitted PEP HW storage facility.

b) Arrangements with Local Authorities: Tooele Army Depot will maintain reciprocal agreements with area fire departments, law enforcement agencies and hospitals. A list of the local authorities that TEAD has agreements with is given in Appendix B of this plan. TEAD has its own fire department and security organizations, which will be the primary responders to emergencies. This plan and others dealing with hazardous waste management are reviewed by these organizations so that they may become familiar with the hazards and properties of the materials, and the facilities at TEAD.

c) Water for Fire Control: Fires fueled by PEP materials or wastes are not fought because of safety reasons. Fires of ordinary combustible items are fought and the following water sources are available: hydrant no. six is located within 1600 ft. of deactivation furnace and supplies 1325 gpm at 101 psi. static pressure. Pumper trucks are also available for fire fighting, and there are several sources of water for refilling, if necessary (see paragraph 2.2 (c) of PEP storage).

### **3.3 Preventive Procedures: Structures and Equipment**

(a) Unloading operations: Proper techniques for transportation and handling as outlined in SOPs include prohibition of smoking and open flames, prohibition of spark producing devices, and use of non sparking tools and material handling equipment.

b) Run-off Control: The facility is fully enclosed. Prior to each day's operation, the interior concrete floor is swept to collect any ash which might be present and the sweeping are managed as hazardous waste.

c) Mitigation of the Effects of Equipment Failure or Power Outrage: If problems develop with equipment or power failure, the feed conveyor will be immediately stopped, and not started until the problems are corrected. Any items remaining in the retort will be processed in the normal manner. In the event of a total power outage, the furnace flame will go out and all conveyors will stop. Feed stock items will be removed from the conveyor in the feed room. Any items, which are in the retort, would be incinerated due to the residual high temperature. If items are left on the conveyor between the retort and outside of the control room they will be left loaded and access will be controlled by ammunition operations personnel until the furnace can be restarted and processing resumed. After the power is restored, the furnace will be restarted and the items in the retort will be collected by the discharge conveyor.

d) Prevention of Contamination of Water Supplies: Contamination of water supplies is prevented by sweeping up any ash or residue from the retort room concrete floor, properly containerizing drums of hazardous waste residues, and promptly responding to spills or discharges. Frequent inspections and training also help to prevent contamination of water supplies.

e) Personnel Protection Equipment: Personnel working at the deactivation furnace are equipped with coveralls and leather gloves. Since the substances processed are non-corrosive and have a low toxicity, other personal protective equipment is not normally used. Spill kits are not provided at the deactivation furnace as no liquid hazardous wastes are present.

f) Precautions to Prevent Ignition or Reaction of Ignitable or Reactive Waste: Proper techniques for transportation and handling as outlined in SOPs include prohibition of smoking and open flames, prohibition of spark producing devices, and use of non sparking tools and material handling equipment. All electrical systems and equipment at the facility are explosion proof.

### **3.4 Inspections and Maintenance**

The emergency equipment is inspected weekly by the operators when the furnace is in use. The decontamination equipment (eyewash) will be inspected and maintained by Ammunition Operations personnel.

## **4.0 Small Caliber Disassembly Line – Bldg. 1325**

### **4.1 Emergency Equipment**

a) Alarm System: Internal communication and alarm is achieved by voice. The facility is small and generally no more than eight people work in the facility at the same time.

b) Device for Summoning External Assistance: A telephone is located in the office of the facility that would be used for summoning external help or emergency assistance.

- c) Access to Communications or Alarms Systems: Whenever the facility is in use, employees will communicate by voice with others present. Employees will use the telephone for summoning external emergency assistance.
- d) Fire control equipment: Portable fire extinguishers are located at the Small Caliber Disassembly Line as shown on the drawing of building 1325 in Appendix A.
- e) Spill Control Equipment: A spill kit containing Tyvek suits, absorbent material, safety glasses or goggles, boots and gloves is located at the Small Caliber Disassembly Line. The location of the spill kit is given in the drawing of Building 1325 in Appendix A.
- f) Decontamination Equipment: An eyewash is located at the Small Caliber Disassembly Line. The location of the eyewash is specified in the drawing of Building 1325 in Appendix A.

## **4.2 Operating Requirements**

- a) Aisle Space: The aisle space (space around the equipment) of the Small Caliber Disassembly Line is shown on the drawing of Building 1325 in Appendix A. The equipment layout was designed to allow easy inspection, maintenance, and removal/replacement of the installed equipment. The spacing is also adequate for spill control activities. No PEP materials are stored at the facility. During operation, only the quantity of PEP materials that are to be processed that day are brought to the feed room. If, for some reason, these items are not processed, they will be returned to a permitted hazardous waste storage facility.
- b) Arrangements with Local Authorities: TEAD maintains reciprocal agreements with area fire departments, law enforcement agencies and hospitals. A list of the agreements is given in Appendix B of this plan. TEAD has its own fire department and security organizations, which will be the primary responders to emergencies.
- c) Water and Fire Control: Fires fueled by PEP material or wastes are not fought because of safety reasons. Fires of ordinary combustible items are fought and two primary water sources are available. A hydrant is located just out the gate to the facility within a few hundred feet of the structure and supplies 1325 gpm at 101 psi of static pressure. Pumper trucks are also available for fire fighting.

## **4.3 Preventative Procedures, Structures, and Equipment**

- a) Unloading Operations: The same procedure and equipment used for unloading at the PEP CSFs are also used at the Small Caliber Disassembly Line. These include: use of spotters for movement of PEP, non sparking lifts and hand tools, grounding, explosive safety training and refresher training.
- b) Run-off-Control: The Small Caliber Disassembly Line is totally enclosed and weather tight. All spills will be immediately cleaned up.

c) Mitigation of the Effects of Equipment Failure or Power Outage: If problems develop with equipment or power failure, the process will be halted and not started until the problems are corrected.

d) Prevention of Contamination of Water Supplies: Contamination of water supplies is prevented by sweeping up any residue or propellant from the disassembly room concrete floor, properly containerizing all materials and waste, and promptly responding to all spills and discharges.

e) Personnel Protection Equipment: Personnel working at the Small Caliber Disassembly Line are equipped with coveralls, leather gloves, and conductive soled shoes. Since the substances processed are non-corrosive and have a low toxicity, other personal protective equipment is not normally used. In the event of a spill, Tyvek suits, safety glasses or goggles, gloves and boots are available in the spill kit.

f) Precautions to Prevent Ignition or Reaction of Ignitable or Reactive Waste: Proper techniques for transportation and handling as outlined in SOPs include grounding of exposed propellant, prohibition of smoking and open flames, prohibition of spark producing devices, and use of non sparking tools and material handling equipment. All electrical systems at the facility are explosion proof.

#### **4.4 Inspection and Maintenance**

The spill control, fire, and decontamination equipment are inspected weekly by the operators when the disassembly line is in use.

If any of the spill control or decontamination equipment is incomplete or deficient the Operators will provide whatever is needed to maintain the spill control equipment. The decontamination equipment (eyewash) will be inspected and maintained by the Ammunition Operations personnel.

### **5.0 Open Burn/Open Detonation (OB/OD) Unit**

#### **5.1 Internal Communications**

The OB/OD Area is serviced with a mobile telephone and a two-way radio. The telephone and the two-way radio are maintained in good working order and checked by Demil Team personnel prior to going to the area.

#### **5.2 Reutilization and External Communications**

Communications with off-site emergency agencies would be conducted by the Installation On Scene Coordinator (IOSC) or the On Scene Commander (OSC). These personnel would be contacted by the Demil Planner, who would be contacted by portable radio and/or mobile

telephone by the Demil Team Leader. The TEAD Fire Prevention and Protection Branch has the capabilities and equipment to respond to Levels A through D (personal protection equipment level) incidents. Response time is no more than 20 minutes.

### **5.3 Fire and Spill Control**

Firefighting equipment is readily available (from TEAD Fire Department) at the OB/OD area during operations. The equipment consists of hand tools and fire extinguishers, filled and approved for use. Additional emergency equipment is stored at the TEAD Fire Department. This equipment includes respirators, protective clothing, fire extinguishers, and first aid kits. TEAD Fire Department personnel, trained in responding to hazardous materials emergencies, have ready access to the area and are dispatched to the scene in case of emergency.

Prior to beginning OB/OD operations, the Demil Team Leader or his designated representative will arrange to have the areas around the operations site cleared of vegetation. Firebreaks are cut around and within the OB/OD area. Access roads serve as firebreaks. After each burn/detonation, the area is swept for fires.

It should be noted that when fires occur within ¼-mile of the area, the Demil Team Leader will not allow workers to engage in fire fighting if the size or condition of the fire would endanger their life or health. The TEAD Fire Department equipment, listed in Appendix E of Attachment 7, is available for incidents.

In addition, the TEAD Fire Department stores and maintains an inventory of spill control and containment materials. This includes shovels, overpack drums and specialized tools. Large quantities of absorbent socks, pads, mats, sheets, bales, pillows, and pulp are also stored in the Fire Station. However, such equipment is not required for the safe management of energetic items treated through OB/OD, as all such wastes are solid materials and thus not subject to spilling. Note, if propellant is spilled, the propellant pieces would be picked up by hand or with a shovel.

The TEAD Fire Prevention and Protection Branch responds to fires and provides the initial response. They evacuate and assess the area. Meanwhile, the members of the TEAD Fire Department start decontamination procedures.

### **5.4 Equipment Testing and Maintenance [Utah Code R315-8-3.4]**

Preparedness and prevention equipment inspection schedules are given in Attachment 4, the *TEAD Inspection Plan*.

### **5.5 Contingency Arrangements and Coordination Agreements [Utah Code R315-8-3.7]**

Arrangements are in place with local police departments, fire departments and hospitals. The IOSC is the primary emergency authority. All decisions concerning the type of emergency response (i.e., firefighting technique, traffic control, medical treatment, isolation/evacuation

requirements, air sampling, spill containment/cleanup) are made by the IOSC and the emergency response team members (see Contingency Plan, Attachment 7 for list of emergency coordinators and designated alternatives).

Ambulance Support is provided by the TEAD Fire Department 24 hours per day every day of the year.

## **5.6 General Hazard Prevention [Utah Code R315-3-5(b)(8)]**

### **5.6.1 Loading and Unloading Operations [Utah Code R315-3-5(b)(8)(i)]**

Motor vehicles and mobile heavy equipment used for transporting ammunition or explosives meet the vehicle unloading requirements in a SOP for the TEAD OB/OD Unit.

- The motor is not started while a magazine door is open. Magazine doors are closed when a vehicle approaches within 25 feet, until the motor is turned off.
- Prior to unloading, the vehicles(s) are turned off, parking brake is set, and vehicle wheels are chocked. Only then are explosive packages, components, and ordnance removed from the truck.
- During unloading operations, compatibility requirements are maintained. Any unloaded initiator, combustible material and fuels are positioned a safe distance from explosives or ordnance.
- Explosives and ammunition are not unloaded or piled immediately in back of the exhaust system of the transporting vehicle.
- All explosive and ordnance containers are spotted and opened at least 10 feet from each other and from previously laid material.
- Packages are opened only when the vehicle is out of the area.
- When the vehicle is completely unloaded, it is withdrawn from the area to a safe location, until completion of the demolition.

Items transported to the OB/OD area are stabilized in boxes filled with sand. Items are packaged in containers of strength equal to or greater than those described in 49 CFR Part 173 Subpart C – Explosives and Blasting Agents; Definition and Preparation. Containers are then transported to the OB/OD Area by Demil Team personnel in government-operated vehicles and offloaded at the silos, pits or burn pans. All containers will be securely stowed to prevent movement during transport. During transport, all vehicles are operated according to strict adherence to U.S. Department of Transportation (DOT) motor courier, state, Army, and local regulations. Drivers are furnished with DD Form 836 (Special Instructions for Motor Vehicle Drivers) which describes the nature of the explosives on the truck, the fire hazards, the methods to be used in

fighting fires involving the truck or cargo, the missile distance in case of explosion, proper distance to maintain from other trucks, and any other information that will bring about safe delivery of the shipment to its destination. Army regulations require that the form be transferred to each subsequent driver and finally to the consignee at the destination. Transport vehicles are removed from the hazard area before the containers are opened.

#### **5.6.2 Runoff [Utah Code R315-3-5(b)(8)(ii)]**

No hazardous wastes are present at the OB burn pans, silos or OD pits except during operations. OB/OD operations are not conducted during periods of precipitation or during flooding. All energetic materials are completely destroyed during detonation, and no hazardous residues are generated. Hence, there is no potential that run-on or run-off from the area will contact wastes or hazardous residues.

#### **5.6.3 Water Supplies [Utah Code R315-3-5(b)(8)(iii)]**

No known drinking water supplies are located within a mile of the OB/OD area.

#### **5.6.4 Equipment and Power Failures [Utah Code R315-3-5(b)(8)(iv)]**

Power outages and lighting strikes are not anticipated to be a cause of problems at the OB/OD Unit. OB/OD operations do not require a permanently installed outside source of electric or other power; therefore, the facility is not subject to power failures. All OB/OD operations are halted or canceled during an electrical storm. Additionally, treatment operations using an electrical firing system are not conducted during sand, dust, or snowstorms. Other natural weather phenomena, such as high winds, are potential problems and are closely monitored. OD will not be conducted when the wind speed is over 15 miles per hour or less than 3 miles per hour and gusts to 20 miles per hour. OB will not be conducted when the wind speed is over 15 miles per hour or less than 3 miles per hour and gusts to 15 miles per hour. OB/OD operations are conducted only within well-defined weather conditions.

If a truck breaks down and cannot be towed to its destination, a guard will be stationed at the truck site. TEAD will dispatch a truck at once with loading personnel to transfer the load to a replacement vehicle.

#### **5.6.5 Personnel Protection Procedures [Utah Code R315-3-5(b)(8)(v)]**

The handling of waste explosives is conducted in a manner that minimizes contact of involved personnel with the waste. All handling operations and requirements for protective clothing are in accordance with SOPs. Protective clothing includes the following items:

- Explosive handler coveralls
- Steel-toed safety shoes
- Safety glasses

Additional equipment may be required by a specific SOP for a particular ordnance item.

#### **5.6.6 Releases to the Atmosphere [Utah Code R315-3-5(b)(8)(vi)]**

Prevention of releases to the atmosphere is not applicable.

#### **5.6.7 Prevention of Accidental Ignition or Reaction of Waste**

All hazardous materials and hazardous wastes handled at the TEAD OB/OD Area are assumed to be reactive, since they are military ordnance and only reactive wastes may be treated at the site. Non-reactive wastes are not treated at this facility. All personnel working in the OB/OD Area must take all appropriate measures to prevent incidents that:

- Generate uncontrolled extreme heat or pressure, fire or explosions or violent Reactions
- Produce uncontrolled toxic mists, fumes, dusts, or gases in sufficient quantities to threaten human health or the environment
- Produce uncontrolled inflammable fumes or gases in sufficient quantities to pose a risk of fire or explosion
- Through any other means, threaten human health or the environment

OB/OD operations generate heat, pressure (shock waves), explosions, and violent reactions. The intent of the OB/OD operations is to initiate these phenomena in a controlled setting. The means to prevent unintended reactions is provided through the establishment of safety guidelines implemented through the TEAD SOPs. As summarized below, the safety guidelines include, but are not limited to, the following:

- Unauthorized ignition sources such as flame-producing devices are prohibited at the OB/OD area at any time
- Sparking equipment and tools are prohibited near explosive materials unless specifically authorized by the Demil Supervisor
- All hand tools and mechanical devices are inspected prior to use to ensure their safety
- Motor vehicles used to transport waste explosives, ammunition, or other material meet the requirements of TE-0000-R-354
- OB/OD operations cease during electrical storms, rain, or snowstorms

- The material is protected against accidental ignition or explosion from fragments, grass fires, burning embers, or the impulse associated with materials being detonated
- Dry grass, leaves and flammable/combustible materials are removed from around the OB/OD area
- Initiators (e.g., blasting caps, primers) and explosives are packaged, transported, and handled separately until placement for treatment
- Engines of transport vehicles are turned off prior to the unloading of munitions.

These SOPs are in use at various Department of Defense OB/OD operations throughout the country. Experience has shown that when they are followed, the danger of accidental detonation or combustion is negligible.

## **6.0 Hydrolysis Facility, Building 1400**

### **6.1 Emergency Equipment**

a) Alarm System: Alarms (audible beeping, alarm messages on control screens) are built into the automated control system alerting the operators to emergency situations. Internal communication and alarm is achieved by voice. The facility is small and generally no more than eight people work in the facility at the same time.

b) Device for Summoning External Assistance: A telephone is located in the office of the facility that would be used for summoning external help or emergency assistance.

c) Access to Communications or Alarms Systems: Whenever the facility is in use, employees will communicate by voice with others present. Employees will use the telephone located in the office for summoning external emergency assistance.

d) Fire control equipment: A portable fire extinguisher is located at the Hydrolysis Facility as shown on the attached sketch.

e) Spill Control Equipment: A spill kit containing Tyvek suits, absorbent material, gloves, boots, face shields, and safety glasses or goggles is located at the Hydrolysis Facility. The location of the spill kit is given the drawing of Building 1400 in Appendix A.

f) Decontamination Equipment: An eyewash and shower is located at the Hydrolysis Facility. The locations of the eyewash and shower are given in the drawing of Building 1400 in Appendix A.

### **6.2 Operating Requirements**

a) Aisle Space: The aisle space (space around the equipment) of the Hydrolysis Facility is shown in the drawing of Building 1400 in Appendix A. The equipment layout was designed to allow easy inspection, maintenance, and removal/replacement of the installed equipment. The spacing is also adequate for spill control activities. No PEP materials are stored at the facility. During operation, only the quantity of PEP materials that are to be processed that day are brought to the facility. If, for some reason, these items are not processed, they will be returned to a permitted hazardous waste storage facility.

b) Arrangements with Local Authorities: Tooele Army Depot (TEAD) will maintain reciprocal agreements with area fire departments, law enforcement agencies and hospitals. A list of the local authorities that TEAD has agreements with is given in Appendix B of this plan. TEAD has its own fire department and security organizations, who will be the primary responders to emergencies.

c) Water and Fire Control: Fires fueled by PEP material or wastes are not fought because of safety reasons. Fires of ordinary combustible items are fought and two primary water sources are available. A hydrant is located just out the gate to the facility within a few hundred feet of the structure and supplies 1325 gpm at 101 psi of static pressure. Pumper trucks are also available for fire fighting. Building 1400 is also equipped with an automatic dry powder fire suppression system.

### **6.3 Preventative Procedures, Structures, and Equipment**

a) Unloading Operations: The same procedure and equipment used for unloading at the PEP CSFs are also used at the Hydrolysis Facility. These include: use of spotters for movement of PEP, non sparking lifts and hand tools, grounding, explosive safety training, refresher training, and OJT.

b) Run-off Control: The Hydrolysis Facility is totally enclosed and weather tight. All spills will be immediately cleaned up.

c) Mitigation of the Effects of Equipment Failure or Power Outage: The facility will be supported with a back-up generator to ensure ventilation systems remain online in the event of a power failure.

d) Prevention of Contamination of Water Supplies: Contamination of water supplies is prevented by the utilization of secondary containment on the hydrolysis, rinse and NAOH product tanks; sweeping up any residue or propellant from the disassembly room concrete floor; properly containerizing all materials and waste; and promptly responding to all spills and discharges.

e) Personnel Protection Equipment: Personnel working at the Hydrolysis Facility are provided for use when appropriate chemical resistant apron, rubber and leather gloves, face shield, boots, and conductive soled shoes. In the event of a spill, Tyvek suits, gloves, boots, face shields and safety glasses or goggles are available in the spill kit.

f) Precautions to Prevent Ignition or Reaction of Ignitable or Reactive Waste: Proper techniques for transportation and handling as outlined in SOPs include grounding, prohibition of smoking and open flames, prohibition of spark producing devices, and use of non-sparking tools and material handling equipment. The ventilation system, which is supported by a back-up generator, ensures hydrogen emissions are maintained below the explosive limit.

#### **6.4 Inspection and Maintenance**

The spill control, fire, and decontamination equipment are inspected weekly by the operators when the facility is in use.

If any of the spill control or decontamination equipment is incomplete or deficient the Operator will provide whatever is needed to maintain the spill control equipment. The decontamination equipment (eyewash and shower) will be inspected and maintained by the Ammunition Operations personnel.

**Appendix A**  
**Location of Emergency Equipment**

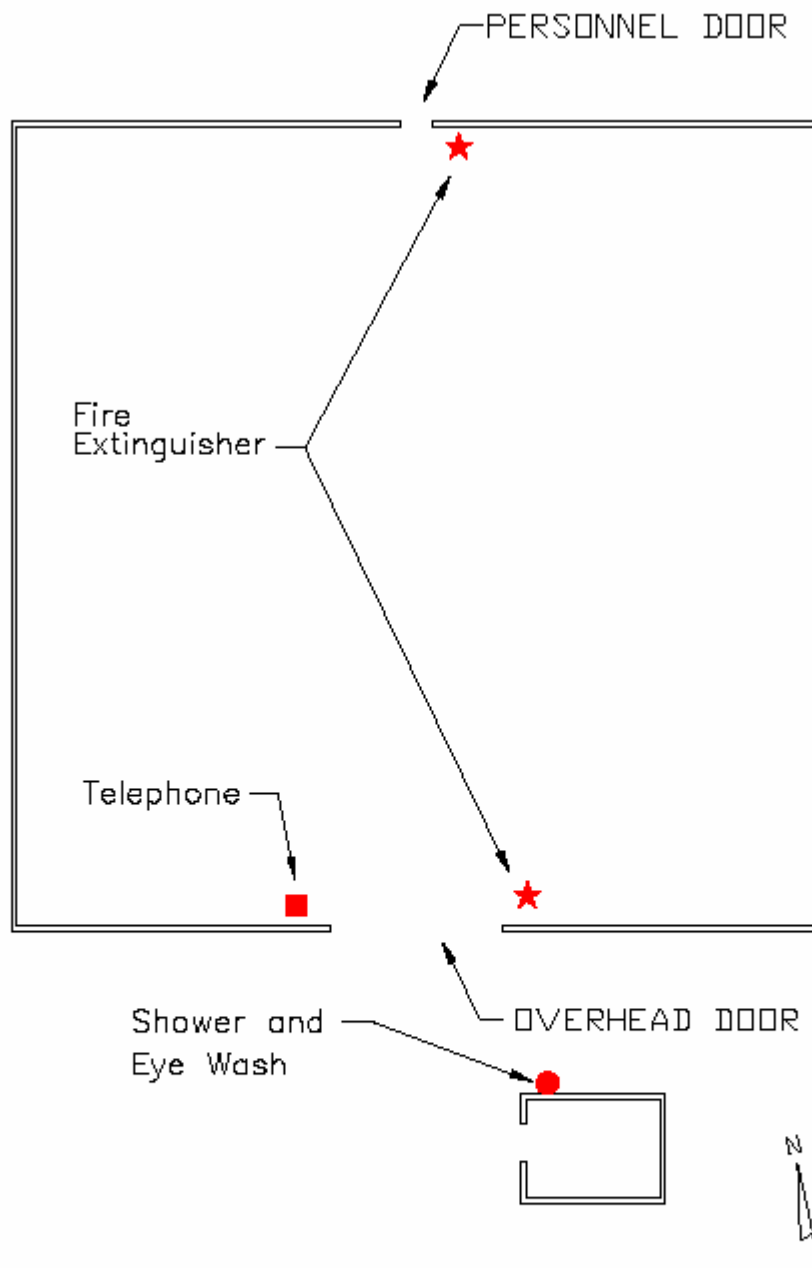

BUILDING 528  
 TEAD CONTAINER STORAGE FACILITY  
 LOCATION OF EMERGENCY EQUIPMENT

Figure A-1

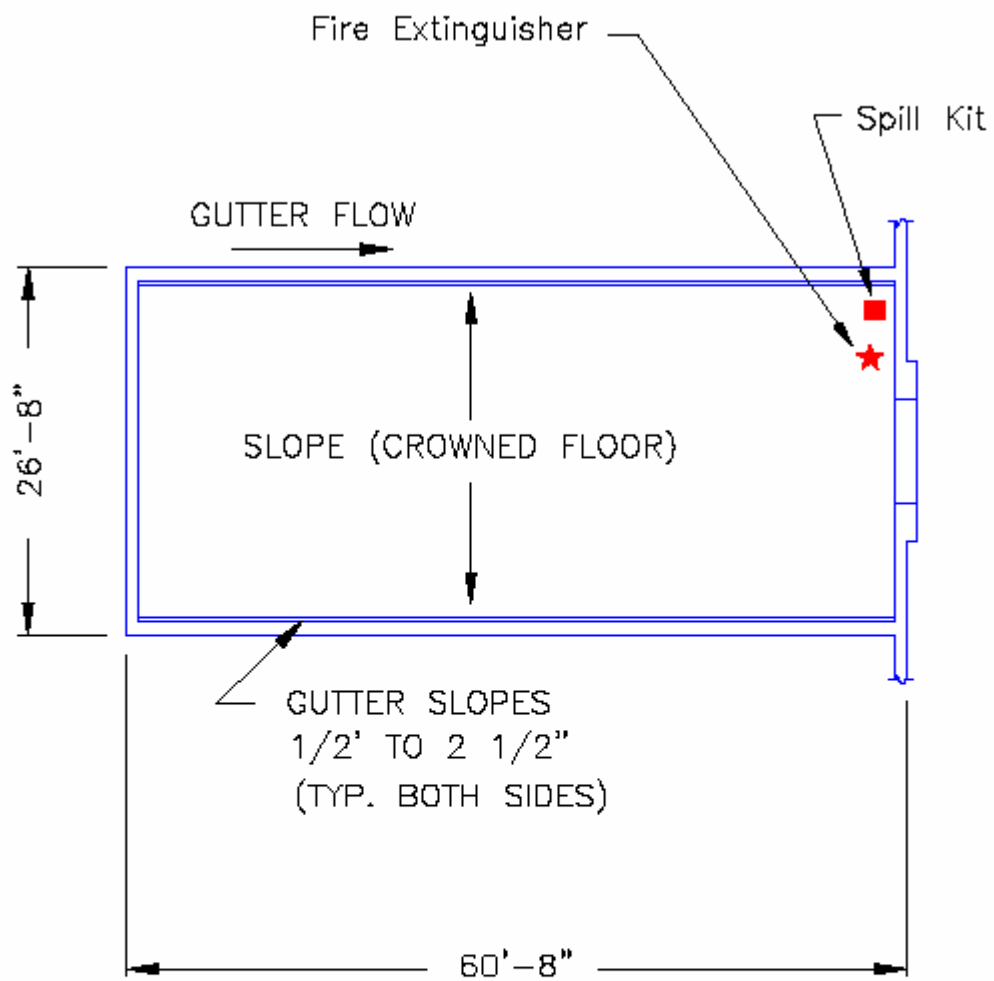

Igloo A-101  
Location of Emergency Equipment

Figure A-2

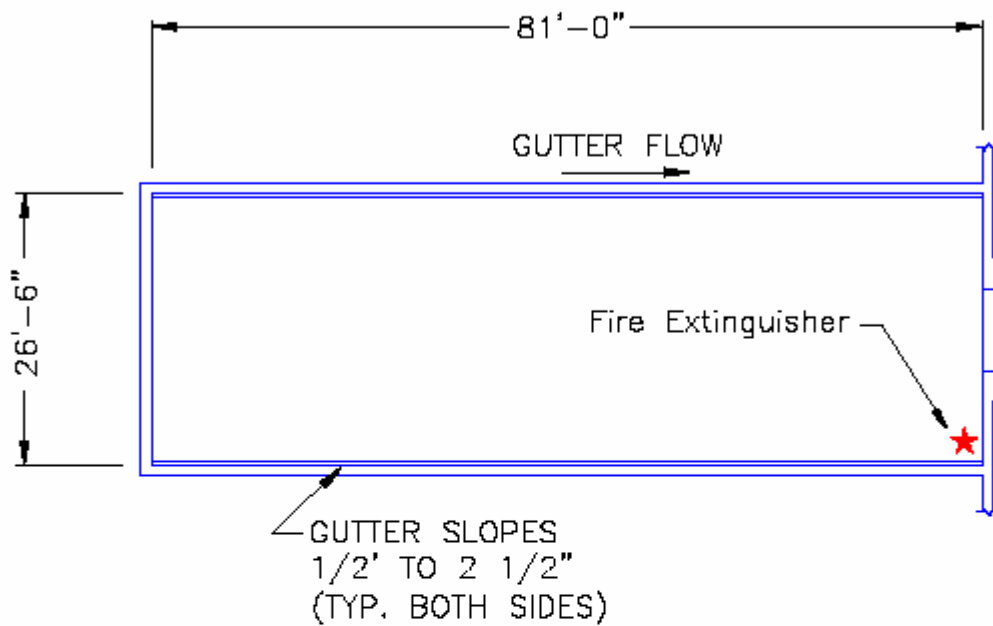

Igloo C-815 & C-816  
Location of Emergency Equipment

Figure A-3

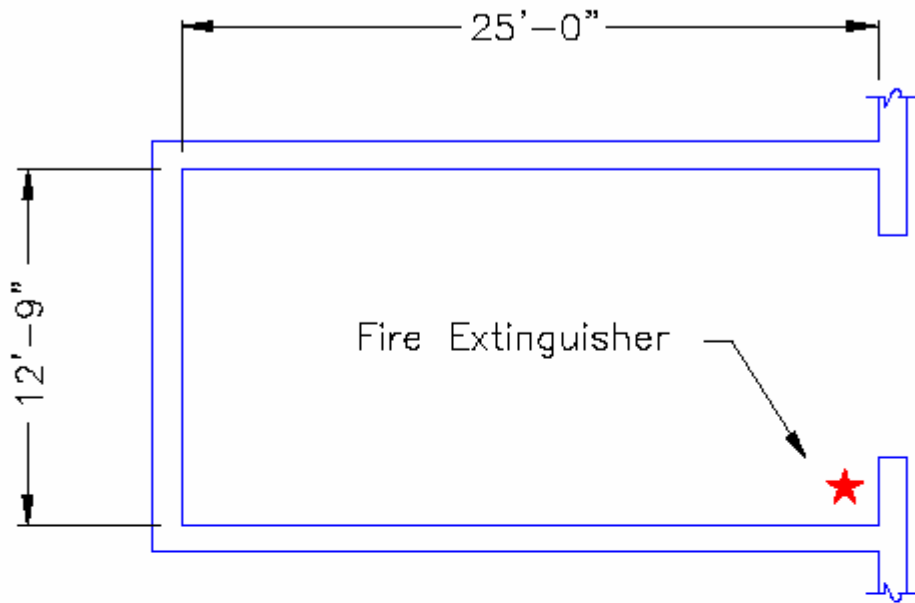

Service Magazines 1368 & 1370  
Location of Emergency Equipment

Figure A-4

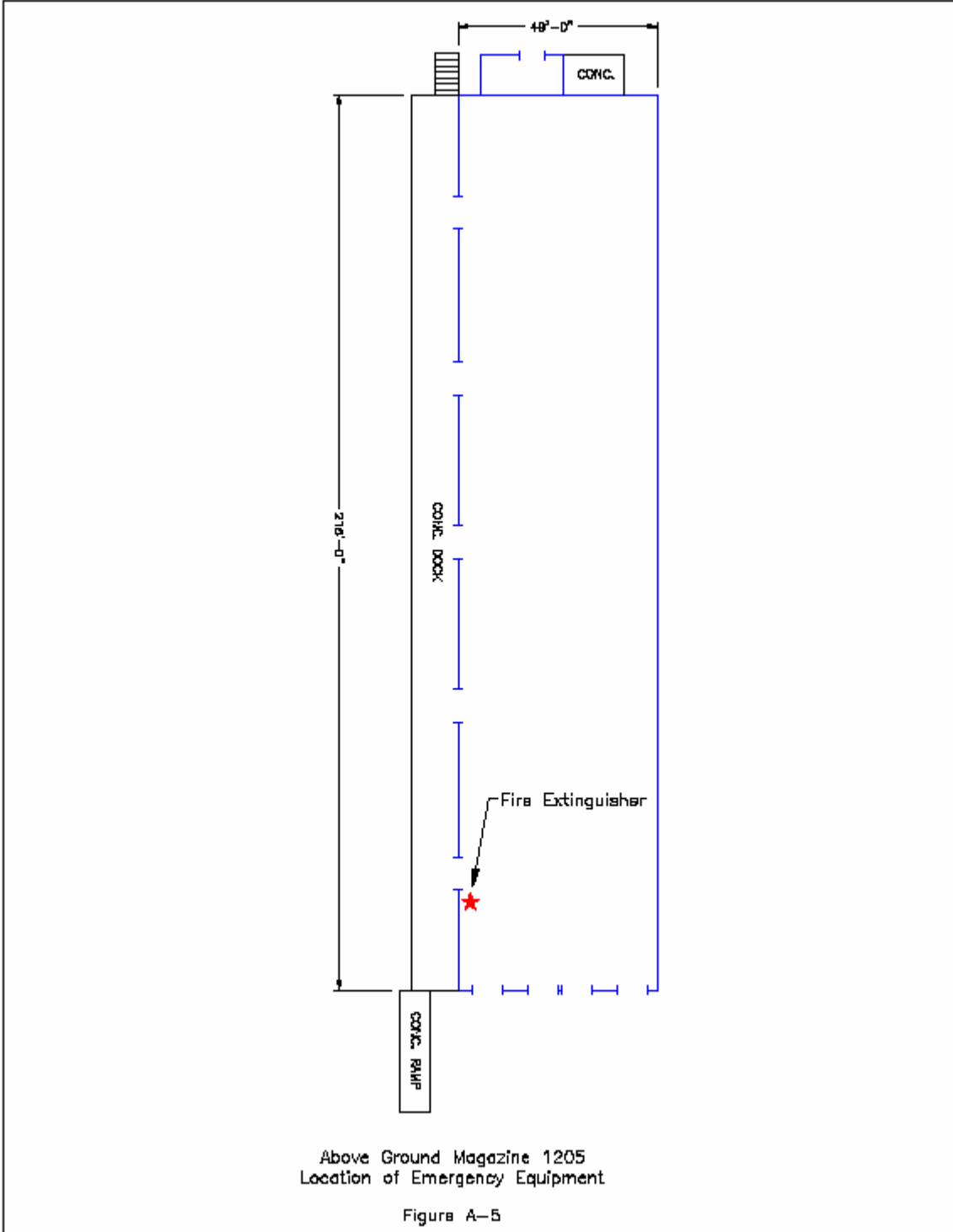

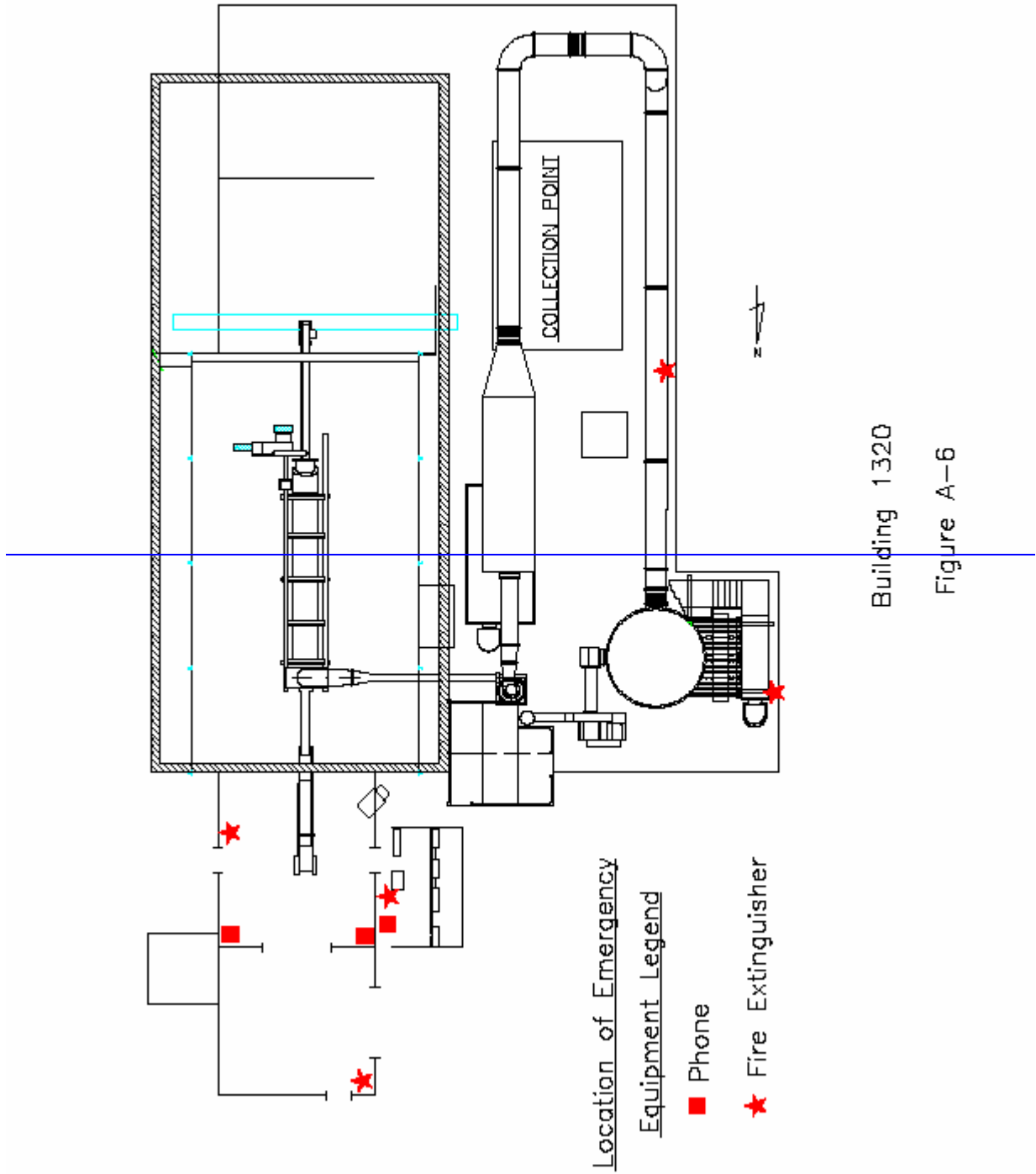

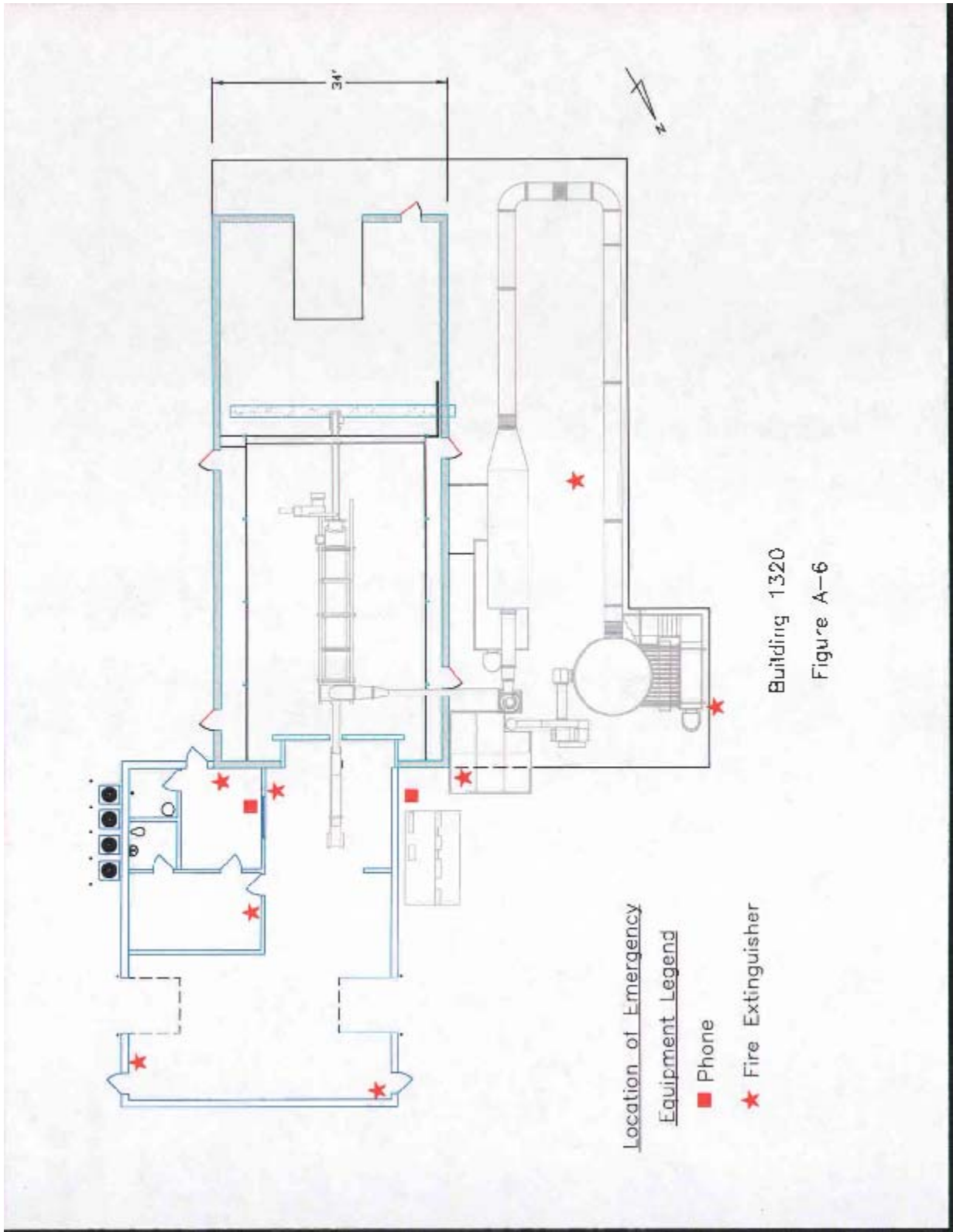

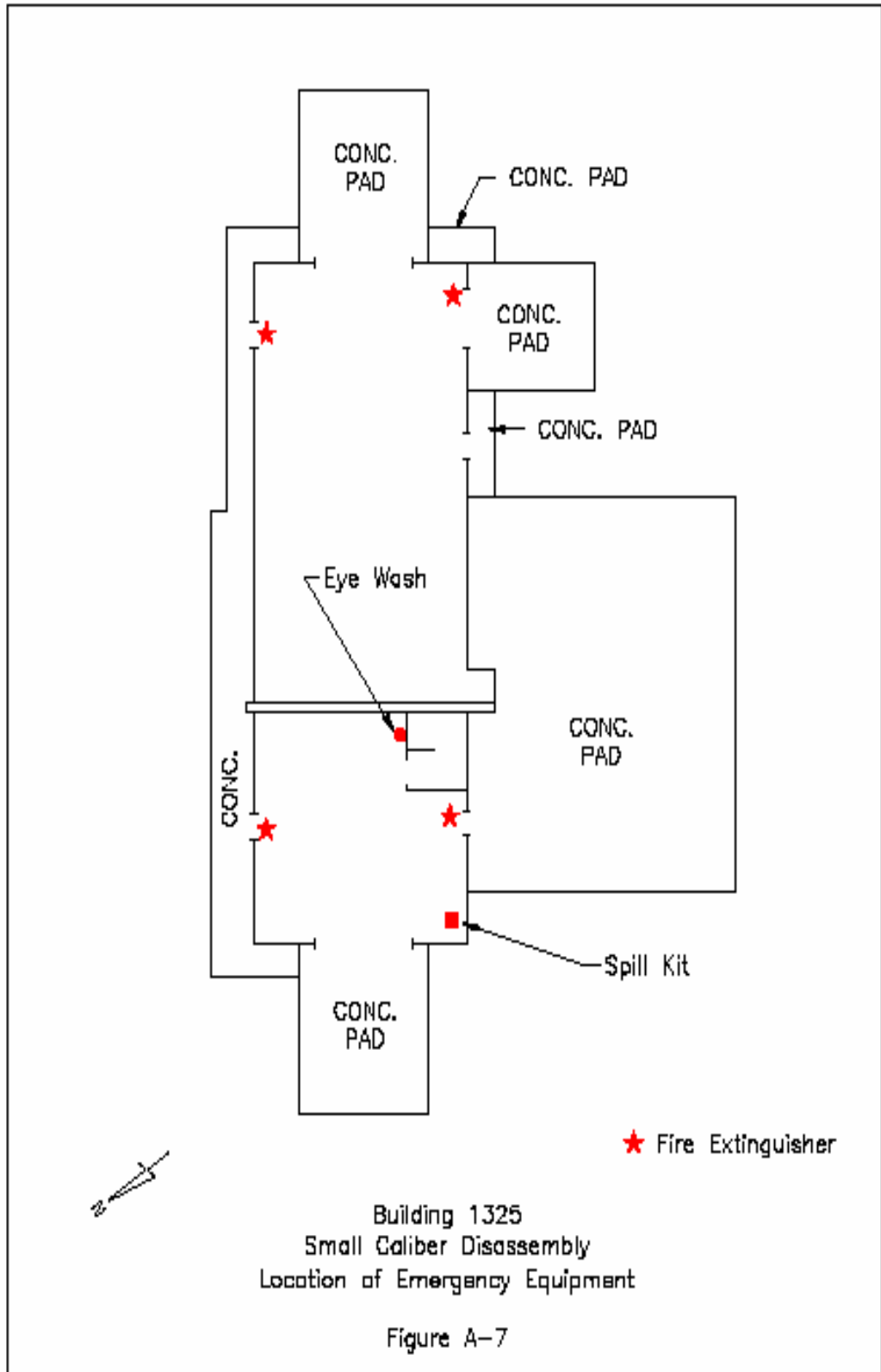

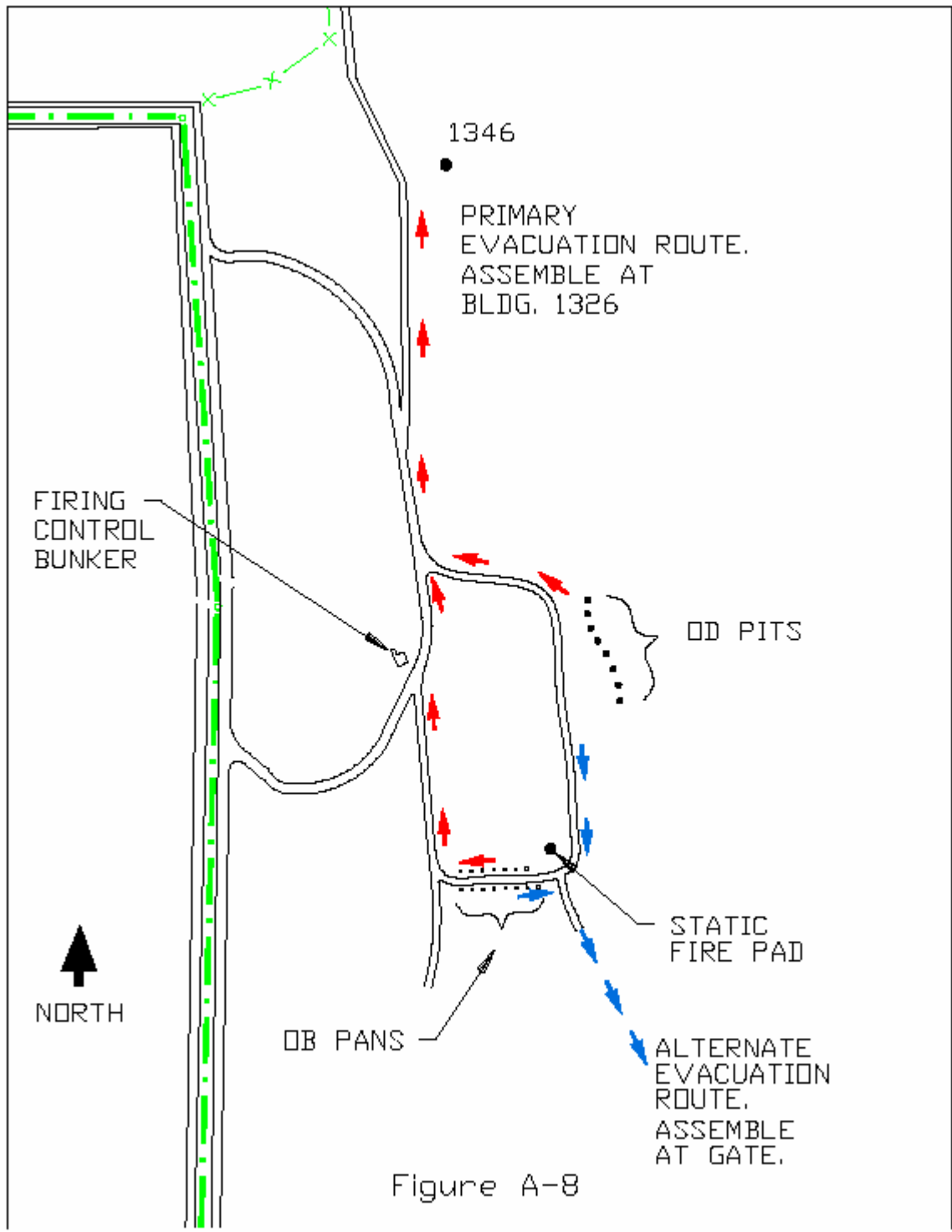

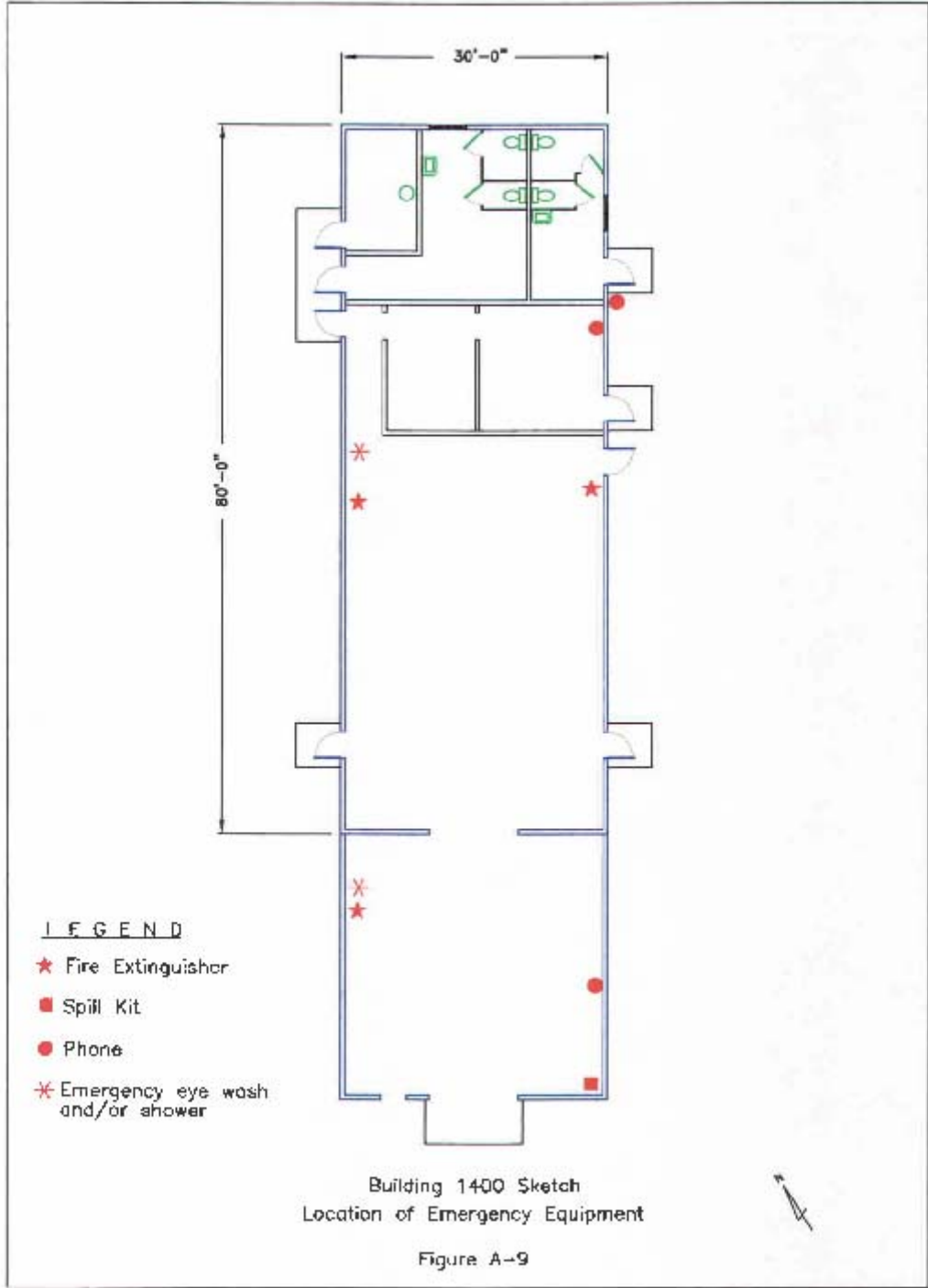

## **Appendix B**

### **List of Reciprocal Agreements**

#### Medical

- Mountain West Medical
- IHC Health Services, INC
- University of Utah Hospital

#### Fire

- Tooele City Fire Department
- Stockton Fire Department
- North Tooele County Fire Department

#### Law Enforcement

- Tooele City Law Enforcement